

天安新材全资控股  
股票代码：603725.SH

**HPL耐火板·浙江瑞欣REXIN**

# MAGNETIC TAIKA/HPL

Magnetic Attraction  
Writing Functionality  
Projection Curtain





## Market Background

## Market Capacity and Functional Demands

Functional demands for wall decoration application scenarios, such as writing, simple mounting of items (e.g. in kitchens, study rooms, and children's rooms).



## Challenges in the Industry

Existing materials have limited functionality, making it difficult to meet the diverse needs of modern users.

Some defects in current materials hinder their usability and adaptability.



Functional Integration: Combines magnetic attraction, writing, and projection capabilities to meet multi-scenario needs.

Eco-Friendly and Safe: Achieves the highest A2 fire resistance rating, E1 formaldehyde emission standard, and is both antibacterial and antiviral.

Durability and Ease of Use: Scratch-resistant and stain-resistant, available in 1.2mm and 3mm thickness options, with adhesive backing or structural adhesive for fast and easy installation.

## Product Innovation



# Core technology

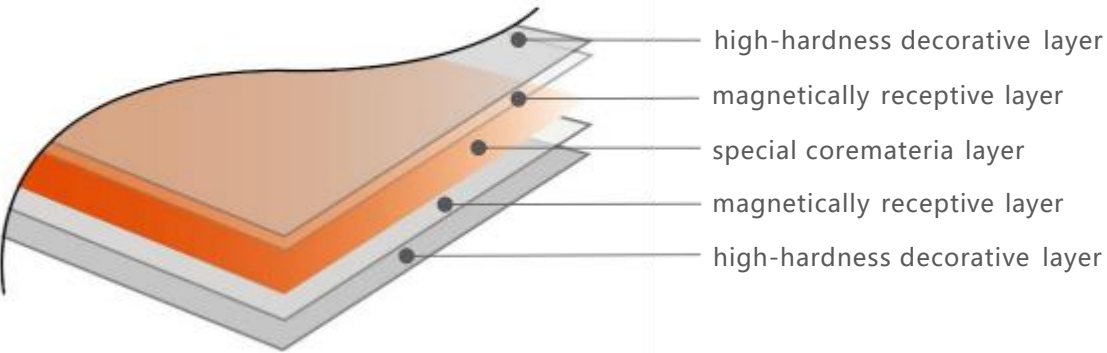

MAGNETIC TAIKA

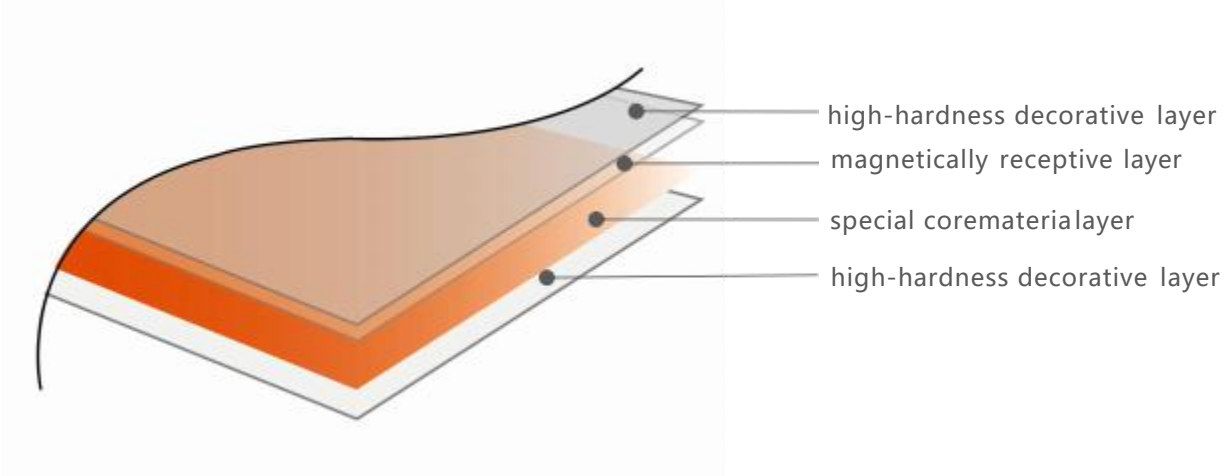

MAGNETIC HPL

Breakthrough Innovation in the Industry – Polymer Core Material with Exclusive Protective Layer

**Product Structure**

## Product introduction

### MAGNETIC HPL

REXIN magnetic HPL are made through high-temperature and high-pressure lamination, combining a writable surface, a magnetically receptive layer, and a special core material. Their unique all-in-one multifunctional design offers a perfect communication solution for creating practical, dynamic, and highly functional interior spaces.





## Product Specifications

SIZE: 1220\*2440MM、1220\*3050MM

MAGNETIC TAIKA THICKNESS : 3MM

MAGNETIC HPL: 1.2MM



## ◆ FUNCTIONAL ADVANTAGE

MAGNETIC ADSORPTION / WRITING FUNCTION / PROJECTION CURTAIN





## Rich In Colors And Patterns

- 1、Independent Magnetic Function - Optional Surface Finishes: F(Textured), M (Matte), G (High-Gloss). Colors are consistent with those of the HPL, excluding color code 10949.
- 2、Magnetic + Writing Combined Function - Optional Surface Finish: G (High-Gloss). Recommended color codes: 11573, 10008.





GREENGUARD



GREENGUARD GOLD



GREENLABEL



DNV EC MED-B+D



ISO14001

## Product Certifications and Tests

### Authoritative Certifications

A2 Fire Resistance/E1 Formaldehyde Emission/Antibacterial and Antiviral

### Performance Tests

Scratch Resistance/Boiling Water Resistance/Strong Magnetic Receptivity/Chemical Solvent Resistance/Stain and Moisture Resistance

### Eco-Friendly

Compliant with International Green Standards/Lifecycle-Friendly





## Product Advantages

- Multiple Functions: Magnetic adsorption, dust-free writing, projection screen compatibility.
- Variety of Styles: Rich patterns and diverse surface treatments.
- Outstanding Performance: Class A non-combustibility, scratch and wear resistance, waterproof and moisture-proof.
- Easy Installation: No drilling or adhesive required for wall mounting.
- Eco-Friendly: E0 low formaldehyde emission, mold-resistant, and antibacterial.



# Product Practical Application Scenarios



Children's Room



Education and Meetings



Kitchen



Study and Office

## Product Design

Meets the aesthetics of modern consumers

Inspiration: A combination of home aesthetics and functionality

Diversified Color Matching: Melad color system and various surface texture options

Customization Options: Personalized size and color matching services available





## Customer Case Sharing



- 1 Medical Field: Zhongshan University Eye Center – Fire-resistant and antibacterial wall surfaces.
- 2 Education Field: A children's education institution – Enhancing teaching interaction.
- 3 Home Scenarios: DIY children's room design – Combining creativity and practicality.

# Product Installation Wall Recommendations

Applicable Environments



Painted Wall



Tiled Wall



Wooden Panel Wall  
Cabinet



Glass Surface



Acrylic Surface



Putty Wall



Cement Wall



Wallpaper Wall



Damaged Wall



Non-Applicable Environments

## The installation methods for magnetic HPL



The standard size of the magnetic HPL is 600\*800\*1.2mm, with customizable dimensions available.

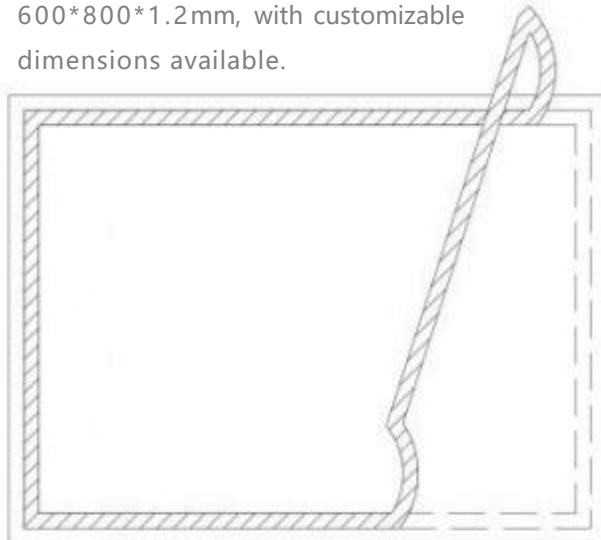

ZZ Adhesive Backing Application Diagram



Product Maintenance:

Do not chop, cut, strike, or hammer on the magnetic wall panel. Avoid using sharp objects to scratch or cut the surface, or applying heavy force with a hammer.

Do not use ceramic or abrasive materials to scratch or cut the magnetic wall panel.

Follow cleaning recommendations—do not use abrasive cleaning agents, steel wool, sandpaper, or scouring pads.

**REXIN**



Facebook



Instagram



REXIN Official  
Website

[WWW.REXINNET.COM](http://WWW.REXINNET.COM)



MAKE HOME YOUR OWN

Be Your Own Interior Designer

Magnetic HPL meet your needs for eco-friendliness, multifunctionality, and personalized design.

Contact us for more information or to book a sample experience.